

FUEL CELL APPLICATION HANDBOOK

PERFORMANCE TESTING AND DESIGN VALIDATION

Overview:

The fuel cell industry is currently undergoing initial commercialization of the technology. Research and design, instrumentation and fuel cell performance testing is central to progress in this sector. From the research and monitoring of various cell chemistries, to the design validation at the module and stack levels, to the system wide production test level, fuel cell testing faces unique challenges. This handbook illustrates typical fuel cell test procedures and architectures.

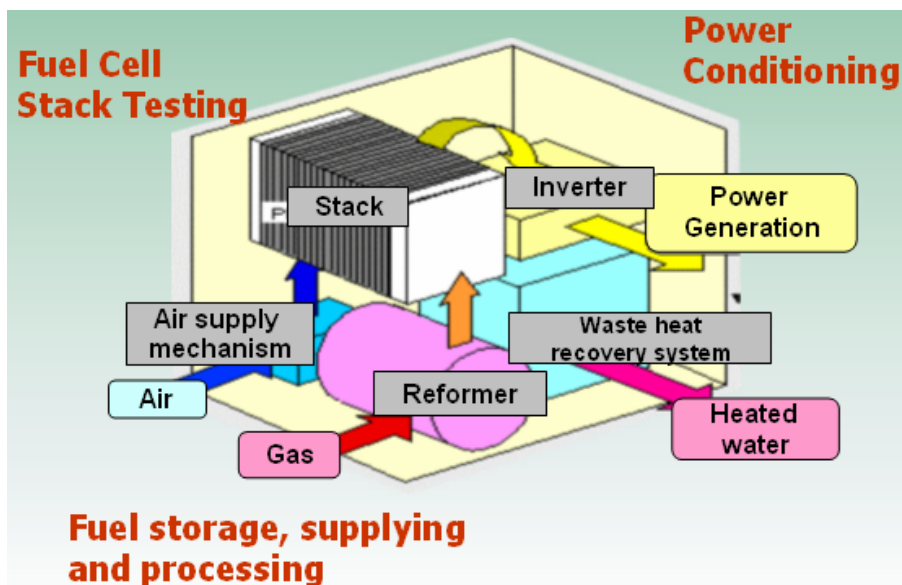

Contents:

1. Fuel Cell System overview	1
2. Cell Voltage Monitoring (CVM)	2
3. Stack Strain Testing	4
4. Temperature profiling	6
5. Process Control and Monitoring	7
6. Software Automation	9
7. Impedance testing with Electrochemical Impedance Spectroscopy	10
8. Impedance testing with Current Interruption	12
9. Cell IMPEDANCE and Inverter EFFICIENCY Testing with Powermeter WT1600FC	13
10. Outline of Impedance Measurement with WT1600FC	14
11. Inverter testing and Power Analysis using PZ4000	15
12. Inverter testing using WT1600	17
13. Inverter testing using WT2030	18

CELL VOLTAGE MONITORING (CVM)

Application:

Because an individual cell generates only 0.8-1.5VDC, cells are arranged in series to deliver sufficient power. A fuel cell *stack* typically consists of approximately one hundred cells; however it is not uncommon to build stacks containing up to six hundred cells, especially for automotive applications. A CVM system tests each cell's voltage while it is in this stack configuration. It can identify problematic cells and characterize long term cell performance in the field or under load.

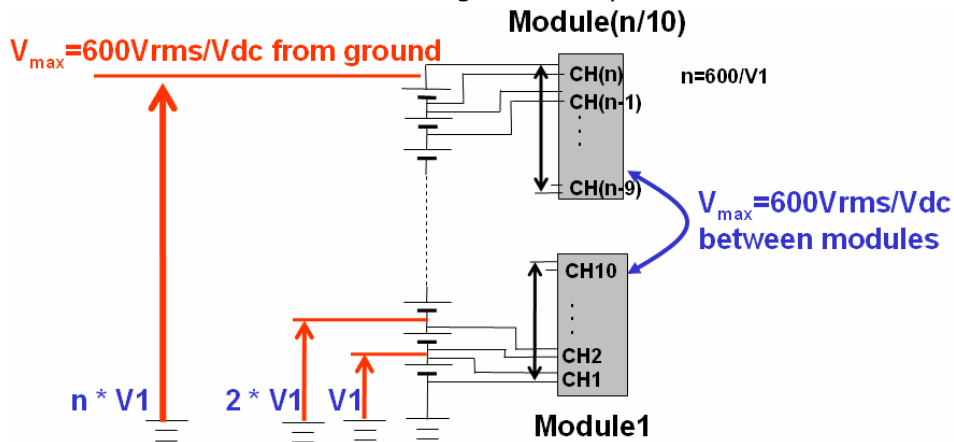

A differential measurement is used to measure each cell voltage. While the cell voltage itself is low level, each leg of the differential input can actually measure hundreds of volts, with respect to the instrument's internal ground. This condition is referred to as **common mode voltage**. Most data acquisition (DAQ) instruments have non-isolated, limited voltage input range before the card is permanently damaged, typically 5 or 10 volts. Additionally, non-isolated equipment is also frequently susceptible to **ground loops**. To overcome the high common mode voltage encountered in fuel cell CVM systems, a **high voltage isolation** barrier is required.

While external signal conditioners or buffers are available from third parties, many DAQ systems nowadays contain internal buffers which minimize the packaging space and cost while maintaining the highest signal resolution and accuracy.

Solution:

The MX100 DAQMaster offers the highest level of channel-to-ground, module-to-module, and channel-to-channel isolation of any solid state DAQ equipment currently available. With it's modular architecture and standard software, MX100 can easily monitor hundreds or thousands of cell voltages.

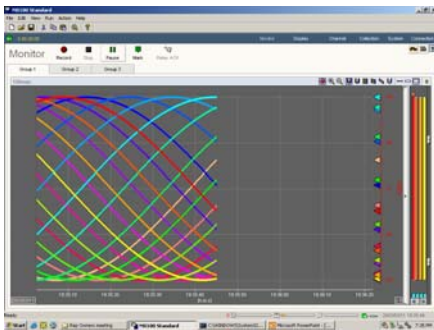

MX100
DAQMaster

CELL VOLTAGE MONITORING (cont.)

Solution:

Achieving high voltage isolation in a DAQ system with a high channel count system is a design challenge, because most data acquisition modules utilize a single A-D converter, with a multiplexing or scanning front end. The high common mode signal must pass through the switching relay before it is isolated and digitized by an **isolation transformer** and A-D converter.

The MX100 employs a patented Yokogawa **solid state relay (SSR)** technology which allows a **continuous load voltage** of 1500VDC. Additionally, the isolation transformer and integrating A-D converters internal to MX100 are also patented Yokogawa designs. Other DAQ systems offering high isolation resort to electro-mechanical relays, which are subject to switch bounce, long setting times, and routine maintenance.

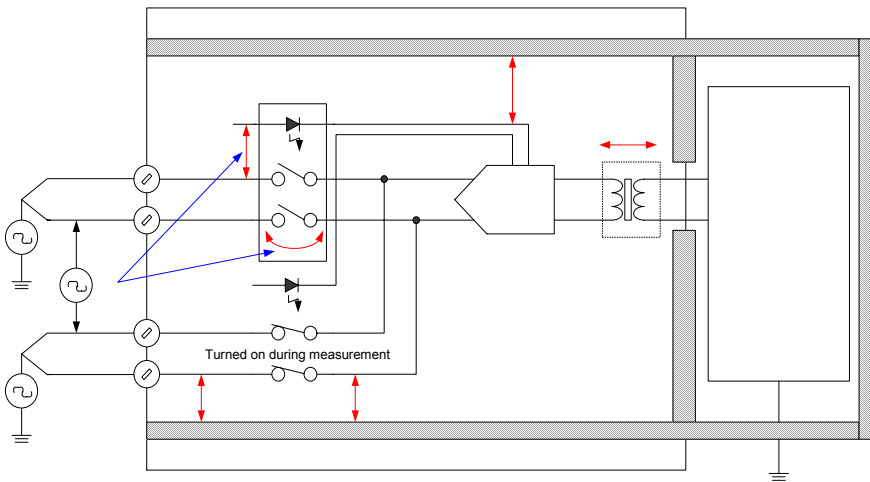

Finally, the MX100 DAQMaster offers an unprecedented level of isolation and performance with a **simultaneously sampled** four-channel module containing independent hardware for each channel.

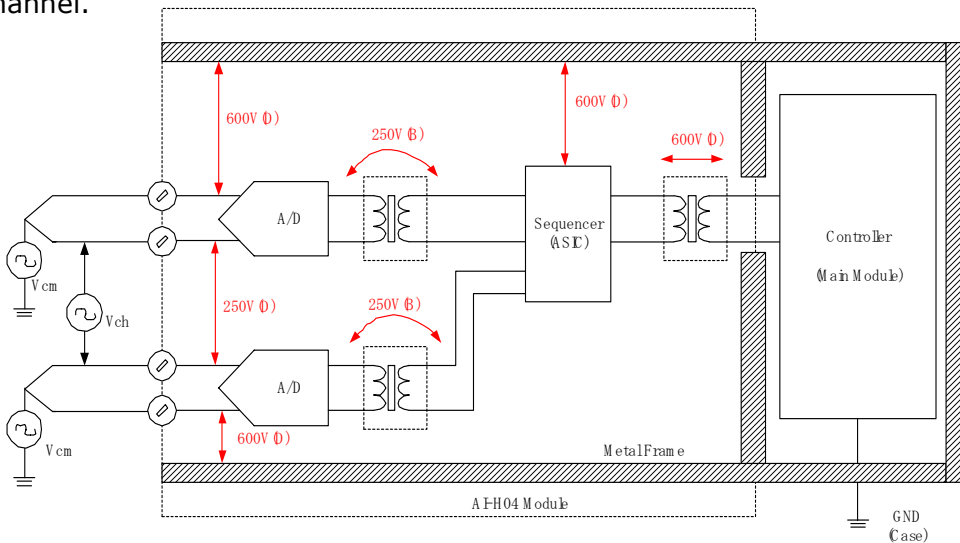

STACK STRAIN

Application:

While fuel cell stacks are held together using relatively simple mechanics, the slightest variation in manufacturing tolerances can result in dramatic losses in performance. Stacks are usually fastened and compressed by screw bolts. The pressure exerted by these bolts affect the stack chemistry and therefore power output.



To test and correlate stack strain with stack or cell voltages, it must first be quantified. The strain gauge sensor is used widely throughout Mechatronics and consumer product test. It consists of a Wheatstone bridge with a combination of four, two or one active gauges. For half and quarter bridge applications, the bridge is completed by using precision resistors.

The completed bridge requires Voltage excitation. Additionally, the measured signal value is typically only a few millivolts, so proper amplification and filtering are required to accurately represent the strain.

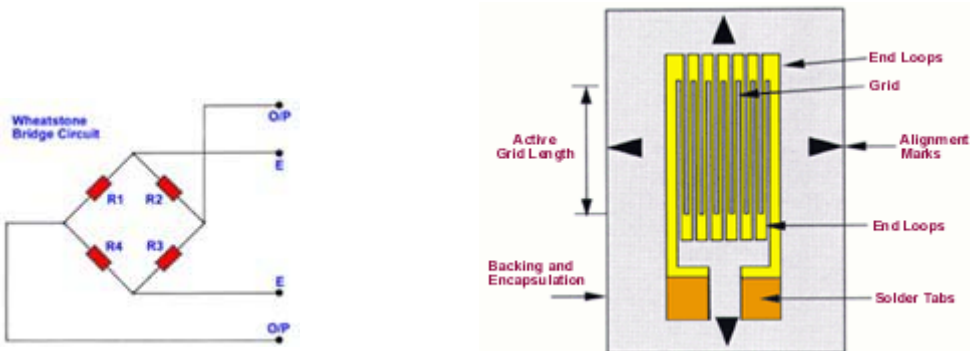

STACK STRAIN (cont.)

Solution:

The WE7000 is a networked, modular data acquisition offering precision measurement and control from a single PC. By using the WE7245 strain gauge measurement module, a system can easily monitor or analyze anywhere from four to hundreds of channels of strain gauges.



Strain Measurement Features:

- 100 kS/sec, simultaneously sampled channels (independent A/D hardware)
- Quarter, Half, and Full Bridge support
- Auto-balancing and shunt calibration
- 120 Ohm, 350 Ohm, or custom bridge head
- Voltage excitation: channel selectable 2V, 5V, or 10V
- Isolated channel-to-channel eliminates ground loops and common mode voltage
- Continuously stream to PC, or use up to one million samples of module memory per channel
- Built-in Hardware low-pass filters for noise rejection
- Each channel can be configured as a voltage input channel for signals other than strain

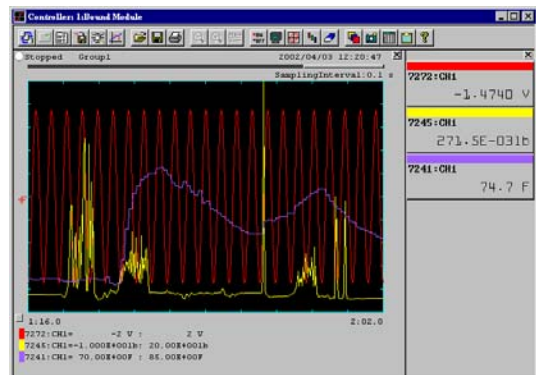

TEMPERATURE PROFILING

Application:

Regardless of the fuel cell technology being used (PEM, SOFC, etc.), thermal monitoring and management is critical to optimize performance and prevent overheating. These temperature measurements apply to all aspects of the fuel cell system, from the stack itself to gas supplies, reformer, inverter, and in some cases co-generation components.

Hence, the thermocouple or RTD channel count can often reach several hundred. For this, a compact, modular, and reconfigurable data acquisition system is ideal.

In addition, thermocouple measurements of fuel cells and inverter outputs, like CVM, are also susceptible to high common mode voltages and the same precautions should be taken to avoid instrumentation damage.

For fuel cell testing, thermocouples are usually chosen over RTDs because of the lower cost and high channel count. At the same time, thermocouple measurement errors can vary with different DAQ systems, from +/- 0.5 deg C up to +/- 5 deg C and more.

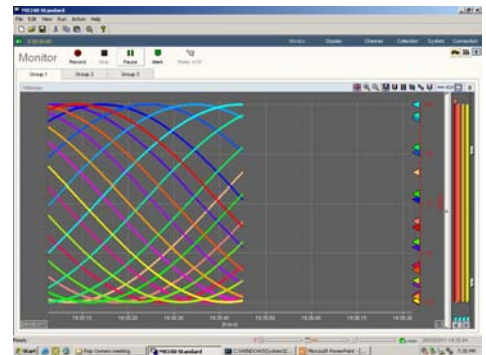
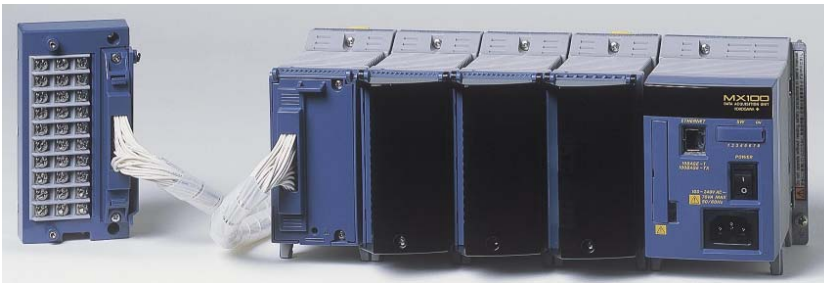

Solution:

The MX100 DAQMaster's versatile universal inputs are designed for a wide variety of thermocouple types. With ten channels per module, the system can easily be scaled to hundreds or thousands of thermocouple channels, all monitored from a single PC via Ethernet.

Temperature Measurement Features:

- R, S, B, K, E, J, T, L, U, N, W, KpvsAu7Fe Thermocouple types supported
- Cold junction compensation
- Open TC / burnout detection
- Support for Remote reference RJC
- 0.1 deg C measurement resolution
- RTD measurement using 1mA or 2mA excitation current
- Pt100, JPt100, Hi-res Pt100, Hi-res JPt100, Ni100SAMA, Ni100DIN, Ni120, Pt50, Cu10GE, Cu10L&N, Cu10WEED, Cu10BAILEY, J263B RTD types supported

PROCESS CONTROL AND MONITORING

Application:

At the core of a fuel cell test station is a process control and monitoring system. Most of these control I/O signals converge into a central PC, which serves as the primary user interface for the tester. Due to the diverse architectures of fuel cell systems and testers, the channel count and sensor layout can vary greatly. However, the signals of interest remain the same: temperatures via thermocouple or RTD, pressure, humidity, flow, and digital I/O.

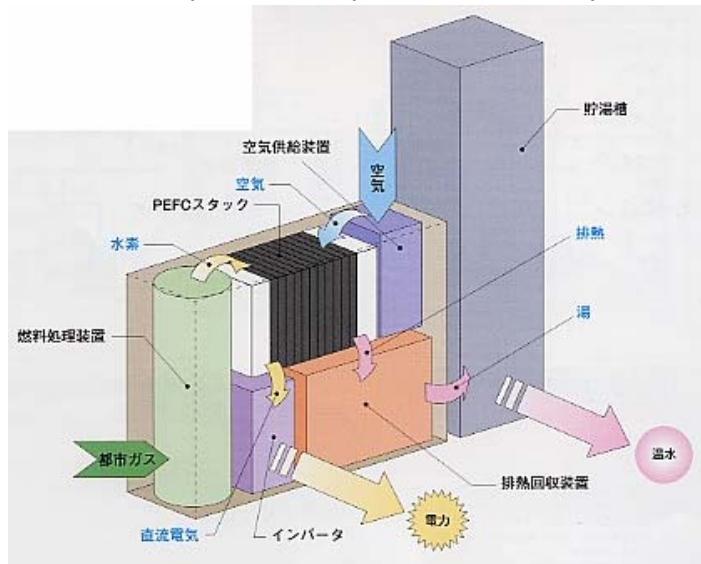

- Reformer: Catalyst temperature
- Air: Pressure, Temperature, Humidity, Flow rate
- Cell voltage, Cell temperature, Gas flow rate
- Hot water flow rate
- Waste heat recovery system: Pressure, Temperature, flow rate
- Inverter system: temperature, cooling air flow rate
- Gas supply: Pressure, temperature, Flow rate

The requirements for architecting the best control I/O system include: a) a distributed topology with measurement nodes, b) a wide variety of configurable inputs and outputs, c) a fail-safe mechanism to prevent data loss or corruption in case of a network or PC failure, and d) strong support for software automation.

Solution:

The MX100 DAQMaster is designed to be controlled via Ethernet. From a single PC, one MX100 main module and backplane (60 channels) can be acquired using a peer-to-peer connection.

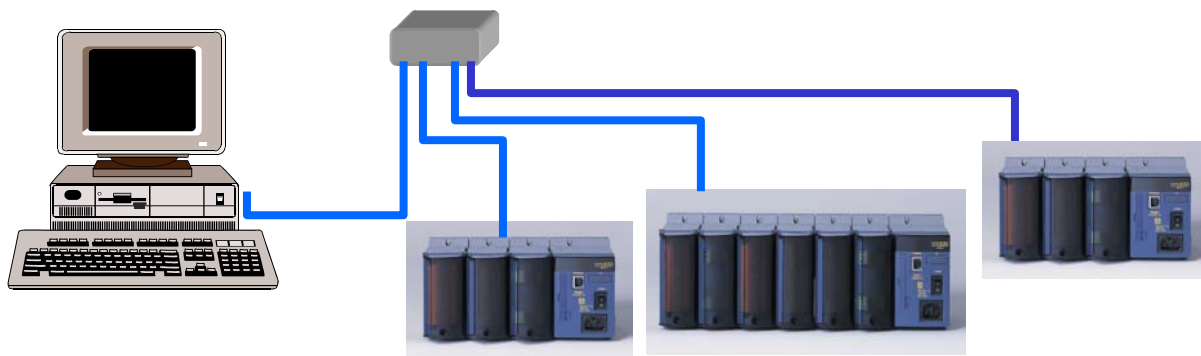

Additionally, the same standalone software allows up to *twenty* MX100 backplanes (1200 channels) be monitored as a single distributed system. By using a programming language such as Visual Basic or C/C++, an even higher channel system can be implemented.

PROCESS CONTROL AND MONITORING (cont.)

Solution:

Because each fuel cell test system is customized, the signal types and channel counts vary greatly. Even within one fuel cell system, control I/O can fluctuate as the design is improved and optimized.

While many data acquisition systems offer modular architectures, where specific modules exist for various sensor types, the MX100 offers **universal inputs** on all input channels. This means that on a channel by channel basis, inputs can be configured as voltage, thermocouple, RTD, and even digital inputs.

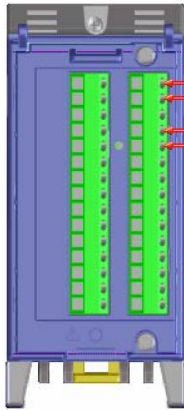

Universal Input channels

Voltage ($\pm 20\text{mV}$, $\pm 60\text{mV}$, $\pm 200\text{mV}$,
 $\pm 2\text{V}$, $\pm 6\text{V}$, $\pm 20\text{V}$, $\pm 100\text{V}$)
Thermocouple
RTD (1mA or 2mA excitation)
Digital Input

Further, each MX100 backplane can independently manage up to three different hardware scan groups. This allows great flexibility in separating fast control I/O parameters (pressure, humidity, flow) from slower control I/O signals (environmental temperature, DC voltage levels, etc.)

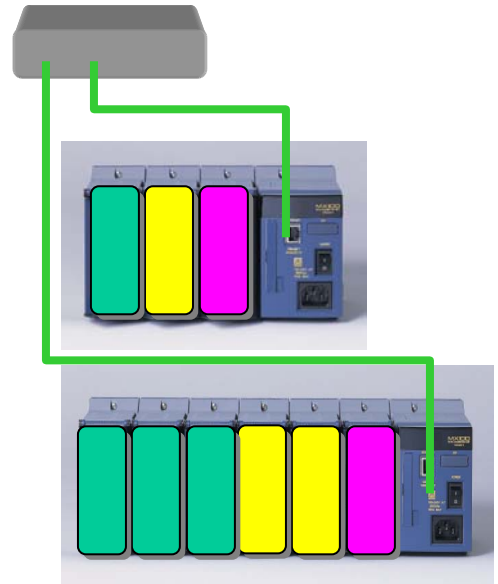

PROCESS CONTROL AND MONITORING (cont.)

By leveraging CompactFlash memory card technology, the MX100 offers the utmost data integrity. It automatically switches data logging from the PC hard drive to the compact flash card when a computer crash or network failure is detected. Upon re-establishment of the link, the acquired data automatically backfills to create a single contiguous block.

For fuel cell testing, the automatic data backup can enable field testing for days or weeks. After initial configuration and start of data logging by PC, the network link can be disconnected so the MX100 is virtually stand-alone.



Software Automation

While the Control I/O portion of fuel cell system primarily consists of one backbone, there are many other controllable components in a fuel cell system which are not part of the main system. To effectively bring all the hardware and communication buses together under one umbrella, most fuel cell testers employ a programming language such as Visual Basic, LabVIEW, C/C++, or a HMI/SCADA package such as Intellution or Wonderware.

The MX100 Control I/O system completely support software automation via these programming packages. Choose from the well documented and high performing dynamic link library (DLL), or integrate using a popular industrial choice-- OLE for process control (OPC).

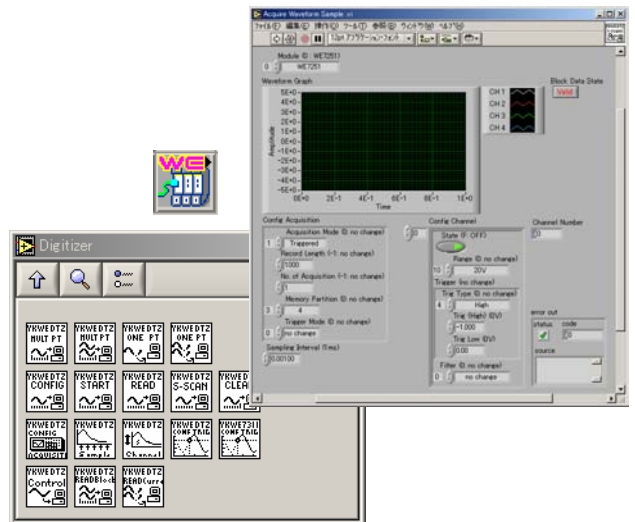
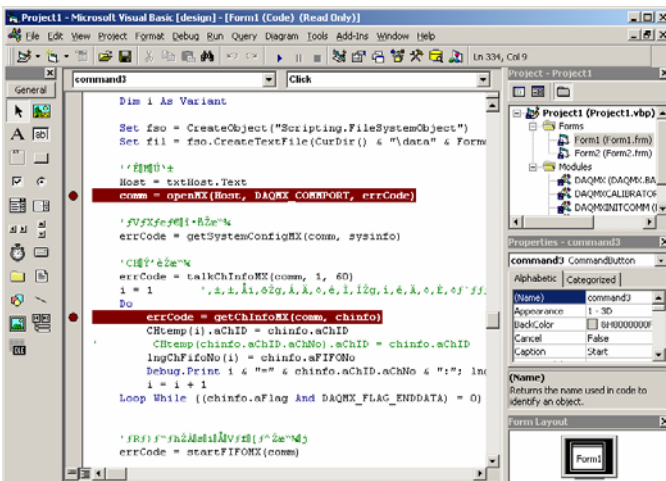

With a distributed topology with measurement nodes, a wide variety of configurable inputs and outputs, a fail-safe mechanism to prevent data loss, and strong support for software automation, the MX100 DAQMaster can effectively serve the Control I/O needs of a fuel cell testing system.

IMPEDANCE MEASUREMENT USING EIS

Application:

Fuel cell impedance characterization is often used to predict the long term performance of a particular stack chemistry or mechanical design. One of the known methods for measuring impedance of a faradaic reaction is called electrochemical impedance spectroscopy (EIS).

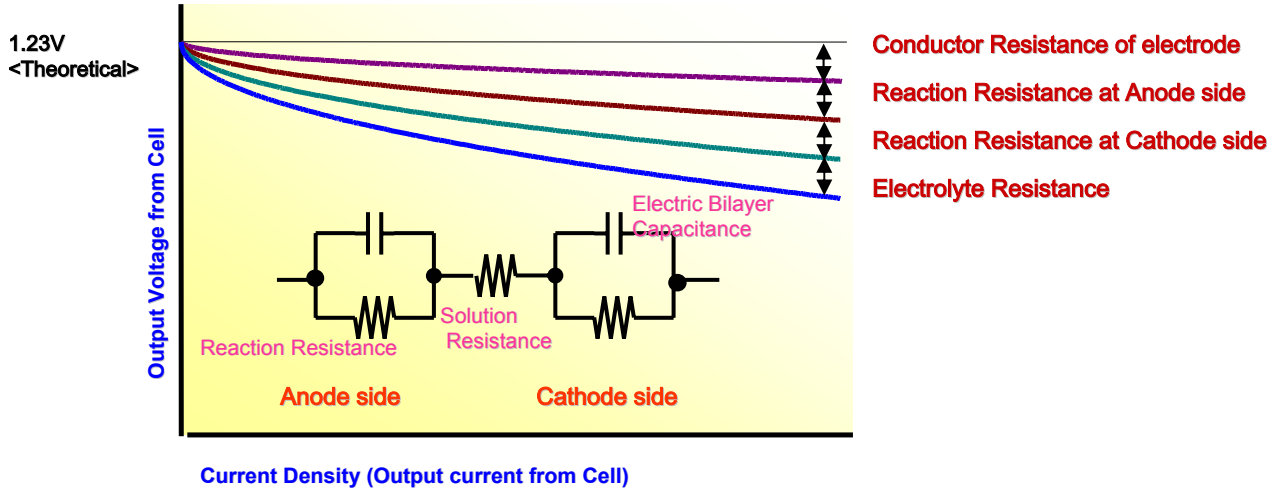

This method involves measuring the cell or stack output voltage while controlling an electronic load. Most electronic loads allow arbitrary control of the set point by an analog voltage.

By superimposing an AC ripple on a DC current, the load will exercise the fuel cell. Then, the response of the fuel cell voltage will vary depending on the solution resistance and bi-layer capacitance as indicated in the equivalent circuit.

Next, by using a data acquisition system with AC coupling for maximum resolution and isolation to eliminate common mode voltage, the signal is acquired. Finally, by using Fourier analysis the actual impedance is recovered, and a Cole-Cole plot can be made.

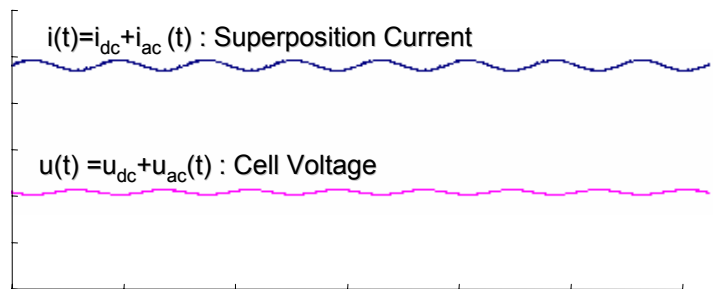
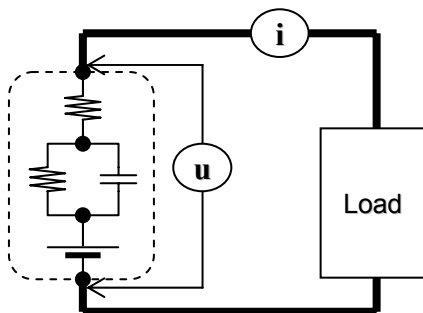

IMPEDANCE MEASUREMENT USING EIS (cont.)

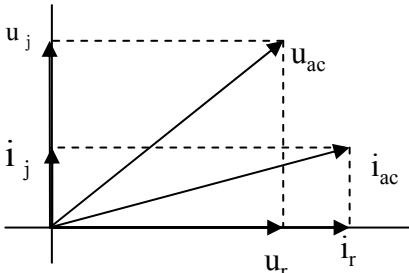

Vector Diagram of Superposition
AC Contents

Calculation for the Impedance with FFT

$$u_r = \frac{2}{T} \int_0^T u(t) \cos \omega t dt$$

$$i_r = \frac{2}{T} \int_0^T i(t) \cos \omega t dt$$

$$u_j = \frac{2}{T} \int_0^T u(t) \sin \omega t dt$$

$$i_j = \frac{2}{T} \int_0^T i(t) \sin \omega t dt$$

$$Z' = \frac{u_r i_r + u_j i_j}{i_r^2 + i_j^2}$$

$$Z'' = \frac{u_r i_j - u_j i_r}{i_r^2 + i_j^2}$$

Effective Power

Reactive Power

Solution:

The WE7000 precision data acquisition platform can handle the superimposition control signal and the fuel cell voltage acquisition from a single chassis.

The D-A output module can operate as a function generator or arbitrary signal generator. It has the ability to generate a hardware sweep of the built-in functions such as sine, triangle, ramp, or pulse.

A wide variety of input modules are available which can sample from DC to 1 GS/sec. However for EIS, a maximum sample rate of 100kS/sec per channel is more than sufficient. These channels are simultaneously sampled, and also offer signal conditioning such as isolation, filtering, attenuation, and most importantly AC coupling.

The standalone software has advanced math expression capabilities; however many fuel cell engineers choose to perform analysis by using math software such as MATLAB.

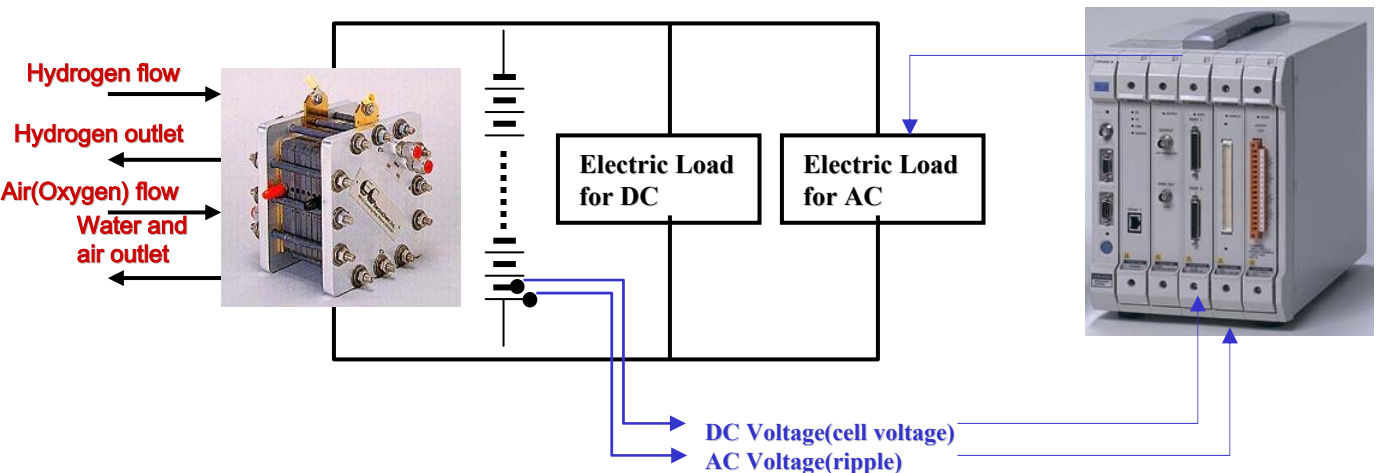

IMPEDANCE TESTING USING CURRENT INTERRUPTION

Application:

Another method of measuring impedance is by using current interruption. This method, while slightly more crude than EIS, is a quick and effective way to measure relative changes in impedance. It is also more commonly used with slow reacting fuel cells such as the SOFC type.

Current interruption involves capturing the voltage spike which occurs in the stack at the moment where the electronic load drops from a fixed value to zero (no load).

Solution:

- A large ringing and overshoot occurs during current interruption
- The Yokogawa DL750 and DL708/716 Digital scopes have versatile hardware low pass filters, averaging functions, and various types of digital filters. With these functions you can eliminate the ringing noise and measure the actual inflection point voltage.
- The DL708/716 and DL750 can each receive a start trigger from the electronic load at current interruption

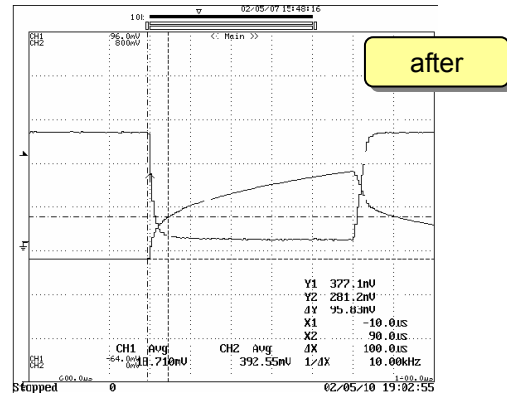
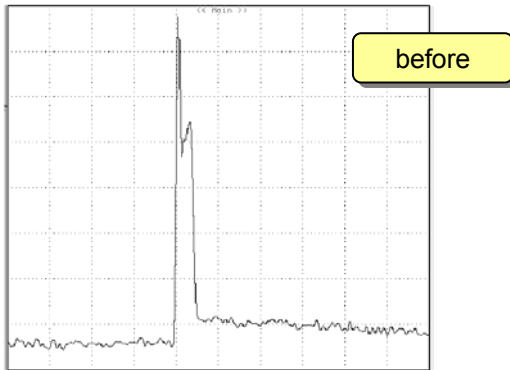
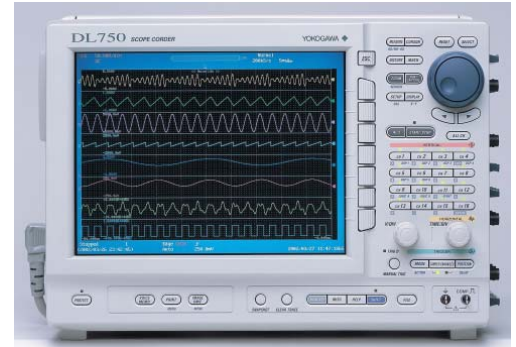

Digital Scope DL750



Prediction of Internal Impedance according to voltage response caused by load current interrupt

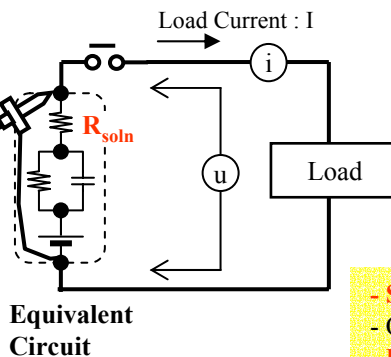

Equivalent Circuit

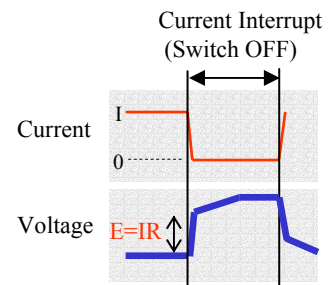

- Simple and Low cost system
- Only R_{soln} (Solution resistance) measurement
- Low Reliability because of waveform analysis
- Noise / Max. Current level / Interrupting speed

Cell IMPEDANCE and Inverter EFFICIENCY Testing with Powermeter WT1600FC

Battery Impedance Measurement

Power and efficiency measurement

Inverter exchanges to AC power
 • Drive a motor
 • As power supply for Home appliances

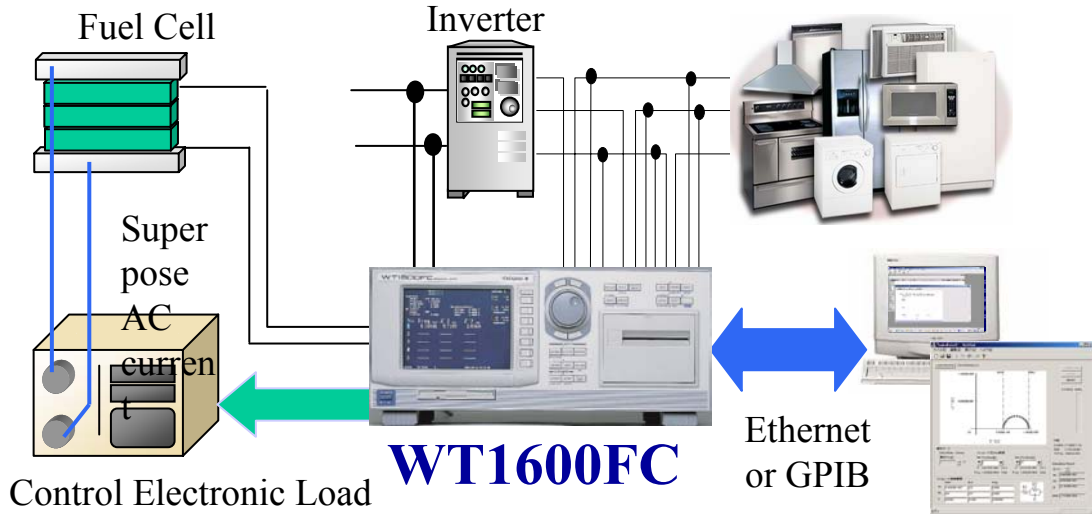

Block Diagram

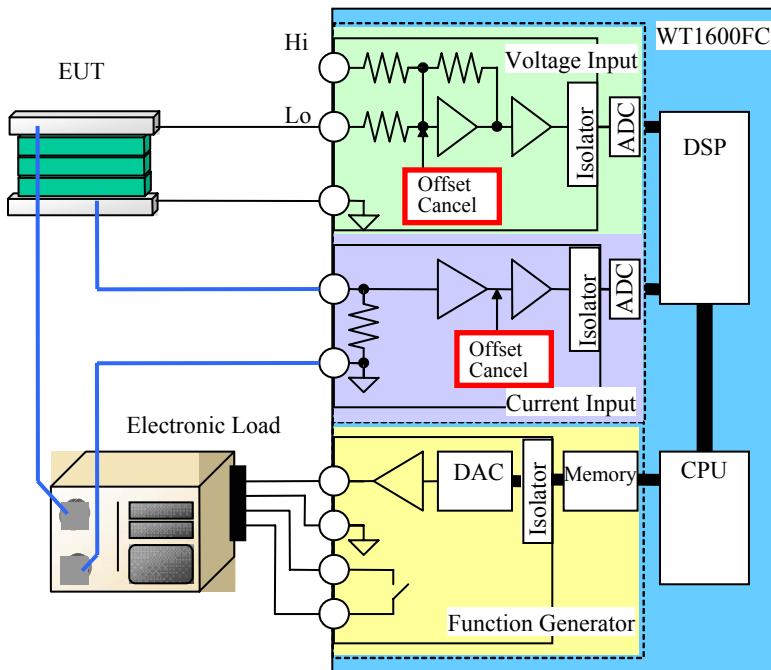

KEY POINTS

- Minute AC voltage and current measurement
- Because frequency response of AC coupling circuit is very poor, WT1600FC uses "Offset Cancel" circuit.
- The circuit does not lose low frequency response (characteristics)

Outline of Impedance Measurement with WT1600FC

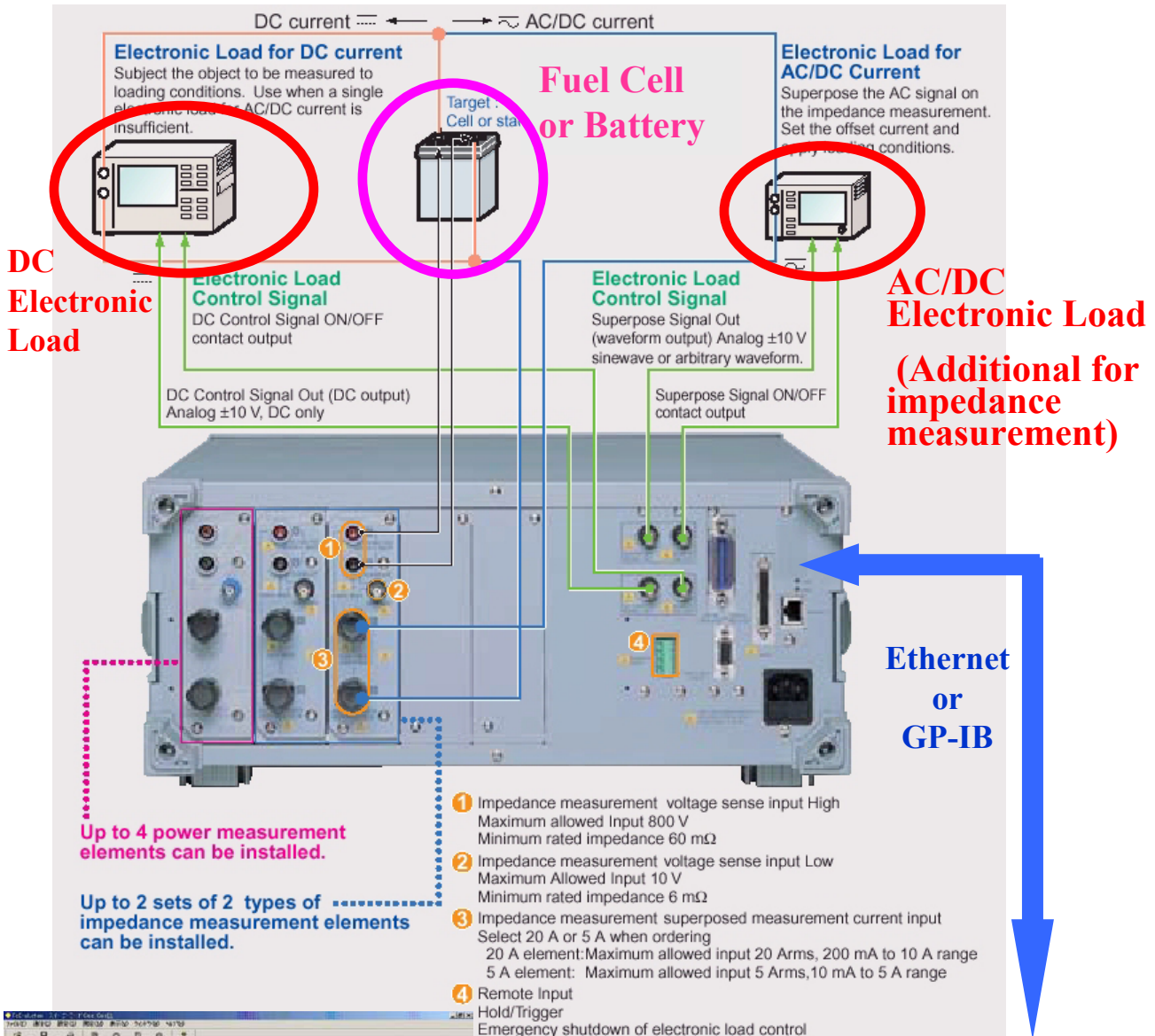

WT1600FC outputs control signals for Electronic Loads and measure impedance continuously.

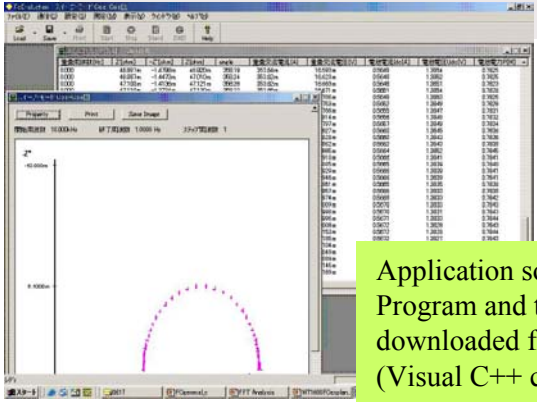

Application software for PC is available. Program and the source code can be downloaded from YOKOGAWA Web site. (Visual C++ code)



INVERTER TESTING USING PZ4000

Application:

Fuel Cell - Inverter power systems can sometimes require Step Load, Transient Response and Transient Overload testing to verify the power conversion characteristics of the inverter. These tests are required to verify the stability of the inverter output under step loads that can occur in normal use.

Solution:

Performance testing for Step and Transient loads requires a high speed power analyzer. A traditional power analyzer that takes samples or “snap shots” of the measurements typically is not fast enough to make these measurements. The Yokogawa Model PZ4000 incorporates a high speed digitizer and acquisition memory to capture these steps and transients without gaps between measurements or loss of data.

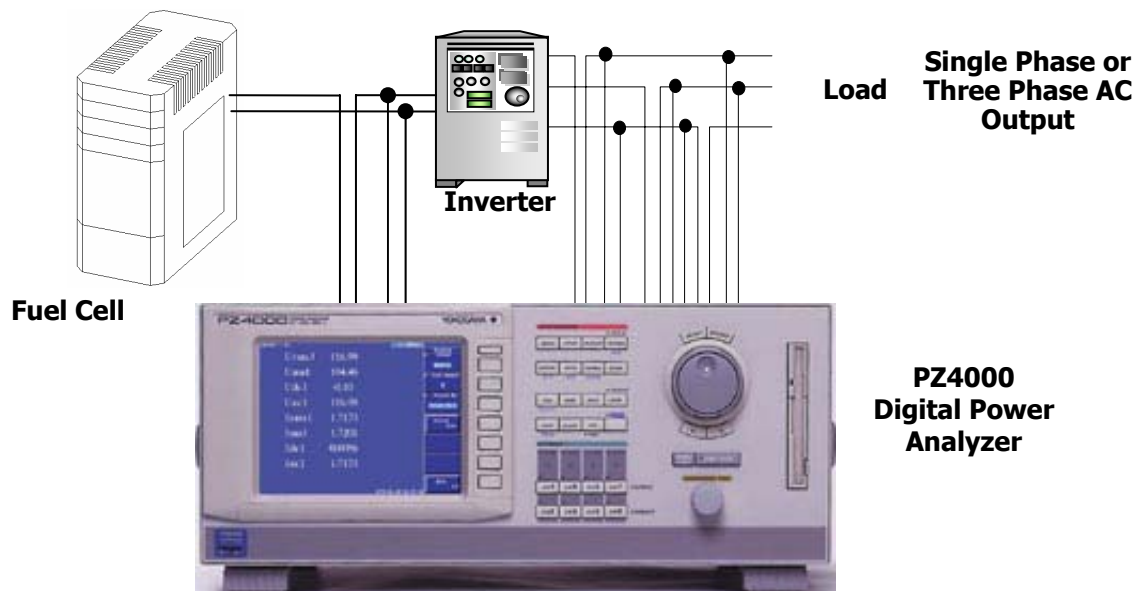

Typical Electrical Measurements:

- Step & Transient Voltage & Current Measurements
- Cycle-by-Cycle Power Measurement
- Voltage & Current Waveform Analysis
- Simultaneous DC & AC Measurements
- Inverter Efficiency & Power Loss
- Harmonic Analysis
- Voltage Distortion
- Voltage Imbalance
- Phase Imbalance
- Voltage Regulation
- Frequency Regulation

INVERTER TESTING USING PZ4000 (cont.)

User Defined Math:

The User Defined Math function in the Yokogawa PZ4000 Power Analyzer allows the test engineer to enter application specific math functions. These math functions can be very useful in the performance testing of the Fuel Cell - Inverter system.

Following are some examples of how the user defined math can be applied:

- % Voltage Regulation
- Inverter Power Loss
- % Frequency Regulation

The screenshot shows the 'User Defined Function 1-4' configuration window. At the top, it displays 'Uover: [green bars]', 'Iover: [green bars]', and 'Rate: 500msec'. The main display area shows 'Urms1 117.89 V' and 'Irms1 0.7501 A'. The configuration table below is as follows:

Function	Unit	Expression
Function 1	V % Reg	$(URMS(E1) - 120) / 120 * 100$
Function 2	W LOSS	$P(E1) - P(E2)$
Function 3	HZ % Reg	$(FU(E1) - 60) / 60 * 100$
Function 4	V/HZ	$UMN(E1) / FU(E1)$

At the bottom, it shows 'U Cnt 3792 T Cnt 1732' and the date/time '2001/04/17 22:15:01'. On the right side, a vertical menu lists various measurement options: Measure, Freq Item, User Defined, Measure, S Formula, Urms*Irms, c Formula, Phase, Lead/Lag, Measure, and Slave.

INVERTER TESTING USING WT1600

Application:

Inverters are a key element in a Fuel Cell powered system that produces AC power. In order to properly evaluate the performance of the Fuel Cell - Inverter system, accurate electrical measurements of the power system must be made under a variety of operating conditions and loads.

Solution:

The performance testing requires accurate measurements of Voltage, Current, Power, Power Factor, Phase and other power parameters. For accurate efficiency calculations, the DC input from the fuel cell must be measured simultaneously with the AC output of the inverter. These measurements must be made with a precision power analyzer in order to ensure accurate amplitude and phase characteristics. Yokogawa offers a complete line of Digital Power Analyzers suitable for the performance testing of the Fuel Cell - Inverter power system.

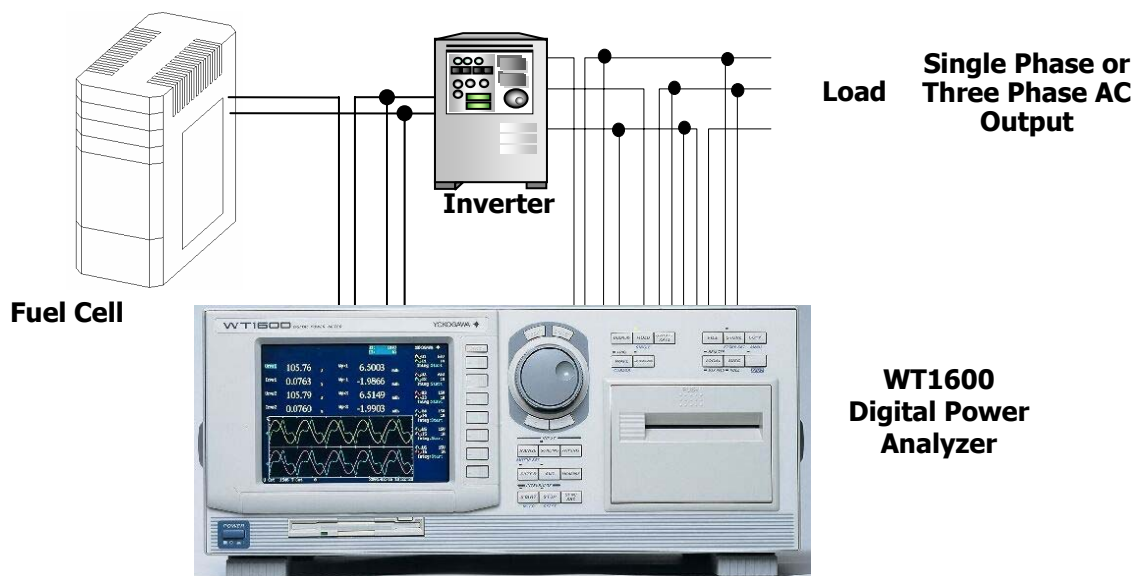

Typical Electrical Measurements:

- Voltage, Current & Power
- Simultaneous DC & AC Measurements
- Inverter Efficiency
- Inverter Power Loss
- Load Characteristics
- Voltage Regulation
- Frequency Regulation
- Power Quality
- Voltage Distortion
- Harmonic Analysis
- Voltage Imbalance
- Phase Imbalance
- Long Term Data Acquisition
- Power Factor, VA, VAR Measurements

INVERTER TESTING USING WT2030

Application:

During the Engineering, Design & Development process of the Fuel Cell - Inverter system, very accurate electrical measurements of the power system must be made in order to verify the performance of the inverter.

Solution:

The WT2030 Power Analyzer provides the highest accuracy measurements of Voltage, Current, Power, Power Factor and other power parameters. For accurate efficiency calculations, the DC input from the fuel cell must be measured simultaneously with the AC output of the inverter. These measurements must be made with the highest precision power analyzer in order to ensure accurate amplitude and phase characteristics necessary to calculate efficiency.

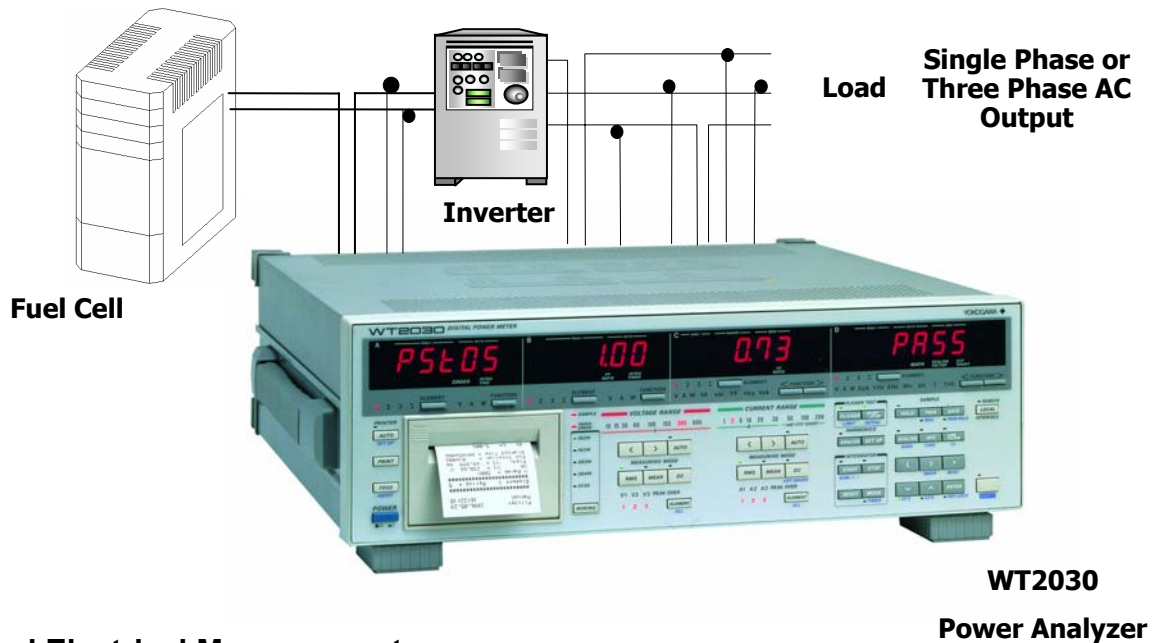

Typical Electrical Measurements:

- Voltage, Current & Power
- Simultaneous DC & AC Measurements
- Inverter Efficiency
- Inverter Power Loss
- Load Characteristics
- Power Quality
- Voltage Distortion
- Harmonic Analysis
- Power Factor, VA, VAR Measurements