

7060

Synthesized Function Generators FG120 & FG110



FG120 (706012)

213 × 100 × 330 mm 3.6kg
(8-3/8 × 4-3/8 × 13" 7.9 lbs)



* Except 706011-1/706012-1
706011-4/706012-4 models



- FG120/FG110
(706011-1/706012-1)
(706011-4/706012-4)
Safety Standards: Certified by CSA
CSA C22.2 No. 231
- FG120/FG110
(706011-7/706012-7)
Safety Standards: EN61010-1
EMC Standard: Certified by KEMA
EN55022 Class B
Immunity Standard: EN50082-1: 1992

Introducing the FG120 and FG110 Synthesized Function Generators from YOKOGAWA.

These models have been developed with the concept of a simplified architecture at a low price.

With emphasis on the most often used functions, the concept allows easy operation and gives you the right signals you need in making evaluations. What's more, direct digital synthesis is used to generate highly accurate signals.

All these features make both of these models the best choice of a signal source in a wide range of applications, from research and development to production.

FEATURES

● Fully Independent 2-Channel Output (FG120)

The FG120 permits you to set up various parameters separately such as the type of waveform, output frequency, amplitude and phase for the two channels which are completely independent of each other.

The phase difference between the two channels can be set in 0.01 degree increments from -10000 to +10000 degrees, which gives you more flexibility for a variety of applications.



● Fully Programmable GP-IB Interface

Each model is designed to allow high-speed control of all panel settings via the GP-IB interface so it can be used in an automated system. Various GP-IB commands are available for your applications.



● Compact in Size With Quick and Easy Operation

We have perfected the technique of assembling components in a compact space to reduce the area of the base to A-4 size.



● Wideband oscillation Frequency of 1μHz to 2 MHz

You can set up the frequency from 1μHz to as wide as 2 MHz with 1mHz or 10-digit resolution. Direct digital synthesis makes highly accurate and stable frequency signals available to you.

● Multiple Operation Modes

The following four output modes are available for each model:

- CONT: Provides continuous oscillation.
- TRIG: Generates a complete waveform any number of times specified (1 to 65536) in synchronization with the trigger signal.
- GATE: Generates a complete waveform any number of times for as long as the gate signal is enabled.
- DC: Generates DC voltages.

● Five High-Quality Output Waveforms

Each model outputs high-quality sine, square (fixed duty cycle of 50%), triangle, ramp, and pulse (variable duty cycle of 5 to 95%) waveforms, along with their inverted forms.

● Maximum Output Swing of 20 Vp-p (at a high-impedance load)

Amplitude and offset can be set for an output level. In addition, high and low levels may be set for any output waveform.

● Variable Starting-and-Ending Point of a Phase

Besides the phase setting between two channels, the starting-and-ending point of a phase in the TRIG or GATE mode can be set separately for each channel.

● Storing/Recalling Panel Setups

Both models can store or recall up to ten different panel setups.

● High Stability Frequency Reference (optional)

A high-stability quartz generator with a frequency accuracy of ±1ppm is provided for your application needs where a highly accurate frequency output is essential.

● Low Distortion Output (optional)

An optional feature for low distortion output is provided for your application needs where high-purity signals or high-accuracy phases are essential.

SYNTHESIZED FUNCTION GENERATORS



FG120 & FG110

FUNCTIONS

■ HIGH-QUALITY OUTPUT WAVEFORMS

● Basic Waveforms

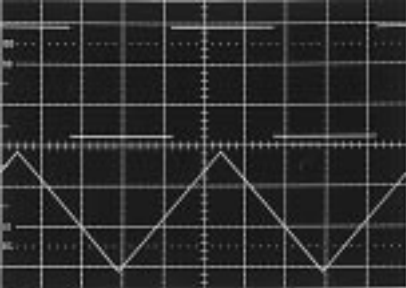

Both models generate basic waveforms - sine, square, triangle, ramp and pulse.

● Variable-Duty Waveforms

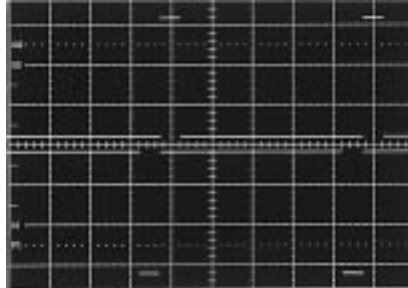

Duty cycle of a pulse waveform can be varied in 0.1% increments from 5 to 95%.

● Variable Amplitudes

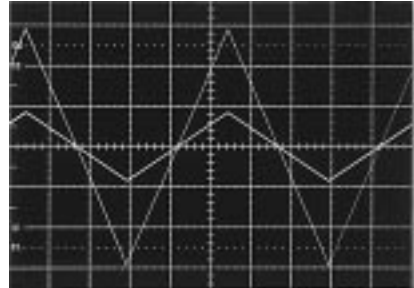

Amplitude is variable and high and low levels can be set separately for each channel.

● Variable Phases

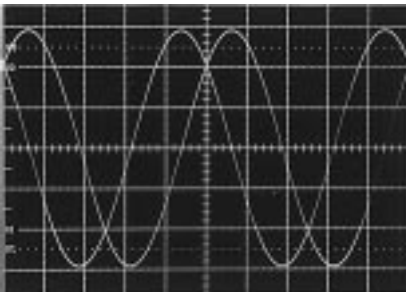

The phase difference between the two channels can be varied in 0.01 degree increments from -10000 to +10000 degrees.

● TRIG Mode

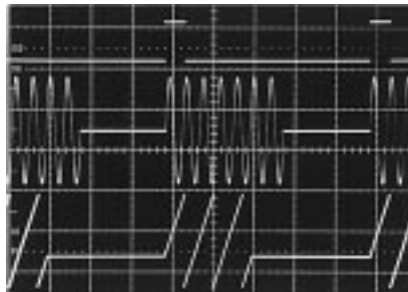

A complete waveform that starts at a preset phase can be generated any number of times from 1 to 65536 specified separately for each channel and in synchronization with the trigger signal.

● GATE Mode

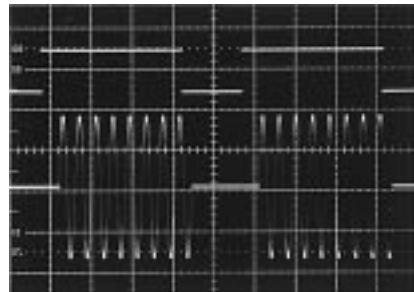

A complete waveform can be generated any number of times as long as the gate signal is enabled. The starting point of a phase can be set separately for the respective channels.

■ BLOCK DIAGRAM

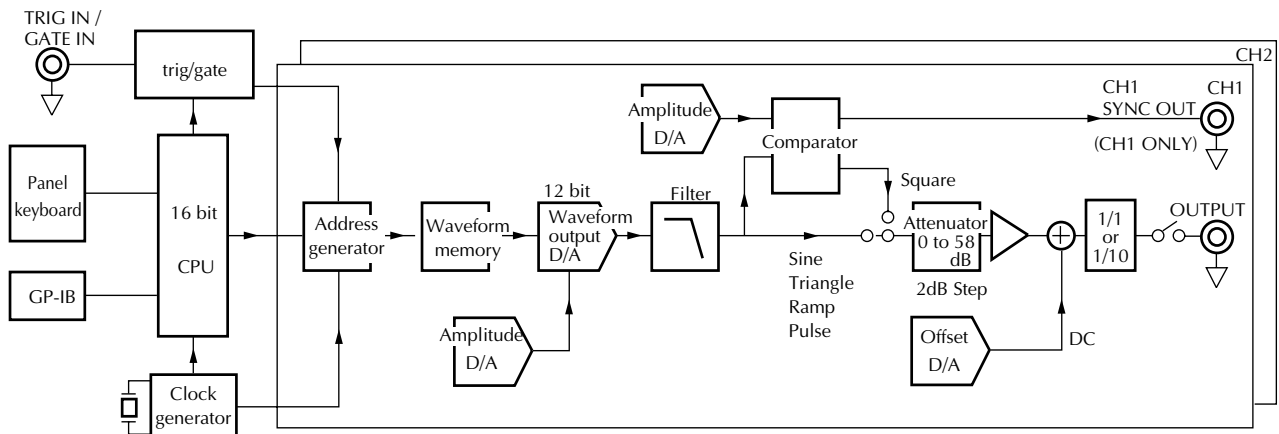

SYNTHESIZED FUNCTION GENERATORS



FG120 & FG110

SPECIFICATIONS

● Output and Operation Modes

Number of channels	FG110 : 1 channel	FG120 : 2 channels
Waveforms output	Sine, Square (fixed duty cycle of 50%), Triangle, Ramp, and Pulse (variable duty cycle from 5% to 95%), and their inverted forms	
Operation modes	CONT (continuous oscillation mode) FG120 : phase-continuous and switchable interchannel synchronization, FG110 : phase-continuous; TRIG (trigger mode); GATE (gate mode); DC (DC mode), where a square wave cannot be selected in the TRIG and GATE modes	

● Frequency

Frequency range	Sine, square: 1 μ Hz to 2 MHz Triangle, ramp, pulse: 1 μ Hz to 100 kHz
Resolution	1 μ Hz or 10 digits
Accuracy	± 20 ppm (± 1 ppm with option code /XTAL)
Stability	± 10 ppm (5 to 40°C) (± 0.5 ppm [5 to 40°C] with option code /XTAL)

● Output Characteristics

Voltage range	Switchable between 1-volt and 10-volt ranges
Maximum output voltage* ¹	1-volt range: ± 1 V (maximum amplitude plus offset) 10-volt range: ± 10 V (maximum amplitude plus offset)
Amplitude setting* ¹	1-volt range: 2 mVp-p to 2 Vp-p (with 0.01 mVp-p or 4-digit resolution) 10-volt range: 20 mVp-p to 20 Vp-p (with 0.1 mVp-p or 4-digit resolution)
Offset voltage setting* ¹	1-volt range: ± 0.999 V (with 0.01 mV resolution) 10-volt range: ± 9.99 V (with 0.1 mV resolution)
Output impedance	50 Ω $\pm 1\%$ (open when output is off)
Amplitude accuracy* ¹	$\pm (0.5\%$ of setpoint plus 0.2% of range): 1kHz sine wave
Amplitude-frequency characteristics	Sine ≤ 10 kHz: ± 0.1 dB Square ≤ 10 kHz: $\pm 2\%$ ≤ 100 kHz: ± 0.2 dB Triangle ≤ 10 kHz: $\pm 3\%$ ≤ 1 MHz: ± 0.5 dB Ramp ≤ 10 kHz: $\pm 3\%$ ≤ 2 MHz: ± 1 dB (RMS values measured at an amplitude of 10 Vp-p, offset voltage of 0 V, 50 Ω load, and scale factor of 0.5, based on a frequency of 1 kHz)
Offset voltage accuracy* ¹	$\pm (0.3\%$ of setpoint plus 0.2% of range plus 0.2% of amplitude setpoint)
DC mode* ¹	1-volt range: ± 1 V (with 0.01 mV resolution) 10-volt range: ± 10 V (with 0.1 mV resolution)
DC mode voltage accuracy* ¹	$\pm (0.3\%$ of setpoint plus 0.1% of range)
Interchannel crosstalk	-70 dB or less (FG120 only)* ²

● Sine-wave Purity (at an amplitude of 10 Vp-p, offset voltage of 0 V, 50 Ω load and scale factor of 0.5)

Harmonics (maximum value in harmonic components from 2nd to 5th order)	10 kHz : -55 dBc or less (-70 dBc or less with option code /DIST1 or DIST2) 100 kHz : -50 dBc or less (-60 dBc or less with option code /DIST1 or DIST2) 2 MHz : -35 dBc or less (-40 dBc or less with option code /DIST1 or DIST2)
Harmonic distortion* ³	10 kHz: 0.3% or less (0.05% or less with option code /DIST1 or DIST2)
Spurious responses* ⁴	100 kHz: -55 dBc or less (-65 dBc or less with option code /DIST1 or DIST2)

● Square- and Pulse-wave Characteristics (at an amplitude of 10 Vp-p, offset voltage of 0 V, 50 Ω load and scale factor of 0.5)

Rise time	Square: 100 ns or less (10% to 90%) Pulse: 200 ns or less (10% to 90%)
Overshoot	Within $\pm 5\%$ of peak-to-peak output value
Duty cycle setting	5% to 95 % with 0.1% resolution (applicable only to pulse waves)
Duty-cycle time accuracy	≤ 10 kHz: $\pm 0.2\%$ of 1/frequency setpoint

● Phase

Phase setting specifications	Setup of the starting-and-ending point of a phase in TRIG and GATE modes and interchannel phase difference
Phase setting range	-10000 to $+10000$ degrees
Phase resolution	0.01 degree
Interchannel offset-phase accuracy	≤ 1 kHz: ± 0.02 degree ≤ 10 kHz: ± 0.1 degree (Sine wave at an amplitude of 9.9 Vp-p, offset voltage of 0 V, 50 Ω load and scale factor of 0.5)

● TRIG, GATE, and Synchronization Outputs

Trigger sources	External trigger, MAN TRIG key, and GP-IB
External trigger input	TTL level with pulse width equal to or greater than 250 ns Switchable rise/fall time Triggering at an interval of 2 μ s or more after waveform generation
External gate input	TTL level with pulse width equal to or greater than 2ms Switchable high/low levels Shares the terminal for external trigger inputs
Synchronization output	TTL level (output impedance of 50 Ω), synchronized with Channel 1

● Other Functions

Setup memory	Capable of storing/recalling up to ten different panel setups using STORE/RECALL key (Non-volatile memory)
Scaling	Displayed by multiplying the voltage setpoint (amplitude, offset voltage, DC mode) by the scaling factor
Preset TTL level * ¹	Sets the amplitude at 5 V and offset voltage at 2.5 V
Copy function (FG120 only)	Copies setup parameters between the two channels (CH1 \rightarrow CH2; CH2 \rightarrow CH1)
Dual function (FG120 only)	Capable of changing setup parameters on the two channels at the same time
Output on/off	Allows both channels to be turned on or off separately

● Communication Functions

Communication function	GP-IB interface (standard)
Electromechanical specifications	Complies with IEEE Standard 488-1978 (JISC1901-1987)
Subsets	SHI, AHI, T6, L4, SRI, RLI, PPO, DCI, DTI, CO

SYNTHESIZED FUNCTION GENERATORS



FG120 & FG110

● General Specifications

Signal grounding	All the grounds of the I/O connectors must be connected to the case grounding.
Operating temperature range	5 to 40°C (41 to 104°F)
Operating humidity range	20 to 80% RH (maximum wet-bulb temperature: 29°C)
Storage temperature range	-20 to 60°C (-4 to 140°F)
Power	90 to 110 VAC or 108 to 132 VAC or 207 to 253 VAC, 48 to 63 Hz
Power consumption	60 VA maximum
Weight	Approx. 3.6 kg
Dimensions	Approx. 213(W) × 100(H) × 330(D)mm

Note: Allow the **FG110** and **FG120** to warm up for more than 30 minutes to obtain the performance specified above.

*1: with high-impedance load

*2: Crosstalk from CH1 to CH2 when 2-MHz sine wave is applied to CH1 and 1.5-MHz sine wave to CH2, respectively, at an amplitude of 10 V_{p-p}, offset voltage of 0 V, 50Ω load and scaling factor of 0.5.

*3: RMS value of harmonic components from 2nd to 5th order

*4: At a frequency range of 1 kHz to 20 MHz

Recommended operating conditions : Temperature: 23 ±2°C, Humidity: 50% ±10% RH, Power supply voltage: 100 V ±1%

AVAILABLE MODELS

Model	Suffix codes	Description
706011		FG110 (1-channel model)
706012		FG120 (2-channel model)
Power requirements	-1	90 to 110 VAC
	-4	108 to 132 VAC
	-7	207 to 253 VAC
Power Cord	-D	UL, CSA Standard
	-F	VDE Standard
	-R	AS Standard
	-J	BS Standard
Optional features	/XTAL	High Stability Frequency Reference
	/DIST1	Low Distortion Output (for FG110)
	/DIST2	Low Distortion Outputs (for FG120)

● Optional Accessories

Name	Code	Description	Order qty
BNC Cable	366924	BNC-BNC, 1m	1
BNC Cable	366925	BNC-BNC, 2m	1
BNC Cable	366926	with alligator clip	1
Conversion Adaptor	366921	BNC plug and banana jack	1
Conversion Adaptor	366927	BNC plug and RCA jack	1
Conversion Adaptor	366928	BNC jack and RCA plug	1
Rack Mounting Kit	751501	EIA single mounting	1
Rack Mounting Kit	751502	EIA double mounting	1
Rack Mounting Kit	751503	JIS single mounting	1
Rack Mounting Kit	751504	JIS double mounting	1

DIMENSIONS

● Common to both the **FG110** and **FG120**.

Unit: mm (inch)

