

# SL1000 HIGH-SPEED DATA ACQUISITION UNIT

NAKAYAMA Etsuro \*1 SUZUKI Satoru \*1 SHINMEN Keizo \*1 UCHIDA Izuru \*1

---

*We have developed the new SL1000 high-speed data acquisition unit which features a maximum sampling rate of 100 MS/s with 16 channels, and yet still offers 1-kV insulation. This PC-based instrument can also update waveforms at a high rate on the PC monitor like a single instrument, even for large quantities of data, due to the newly developed GIGAZoom Engine for data compression. This paper describes the functions and technologies of the high-speed data acquisition in the SL1000.*

---

## INTRODUCTION

Computerization is accelerating in the mechatronics field such as automobile. With hybrid engines for instance, high-efficiency and high-voltage inverter motors are used to aid engine output to conserve energy. In addition, by using numerous ECUs (Electronic Control Units), parts are controlled finely to enhance performance.

In this way, demands for measurement of high-speed and high-voltage electrical signals are growing in the fields of mechatronics and power electronics along with measurements of comparatively low-speed mechanical or physical phenomena.

In response to such demands for high- and low-speed complex measurement, Yokogawa has provided waveform measurement devices such as DL750 and WE7000 for mechatronics. To meet further high-speed measurement and high insulation measurement demands, we have developed a new high-speed data acquisition unit SL1000 based on PC-based measurement, and a new measurement module of 1-kV allowable common mode voltage at the rate of 100 MS/s. The details are discussed in the following. Figure 1 shows the external view of the SL1000.

## CONFIGURATION

Figure 2 shows the overall block diagram of the SL1000.

Input signals are normalized at the attenuator (ATT) and amplifier (AMP) inside an input module, and then digitalized at

the A/D converter. The digitalized signals are isolated at the isolation device between the input part and main unit, and sent to the GIGAZoom Engine (high-speed data compression engine) in the main unit. The main unit has eight slots for input modules, with each slot having two channels, thus enabling up to 16 channels to be simultaneously measured. The input modules include the newly developed high-speed 100 MS/s 12 bits isolation module 720210 as well as eleven DL750 modules. There also are modules which can directly connect with the sensors for measuring not only voltage signals, but physical quantities such as voltage of thermocouple (temperature), strain, acceleration, and so forth.

GIGAZoom Engine carries out all operations related to data acquisition: timing to control the A/D converter in the input module, detecting trigger, writing converted data from the A/D converter into the acquisition memory, managing the acquisition



Figure 1 External View of the SL1000

---

\*1 Communications and Measurement Business Headquarters

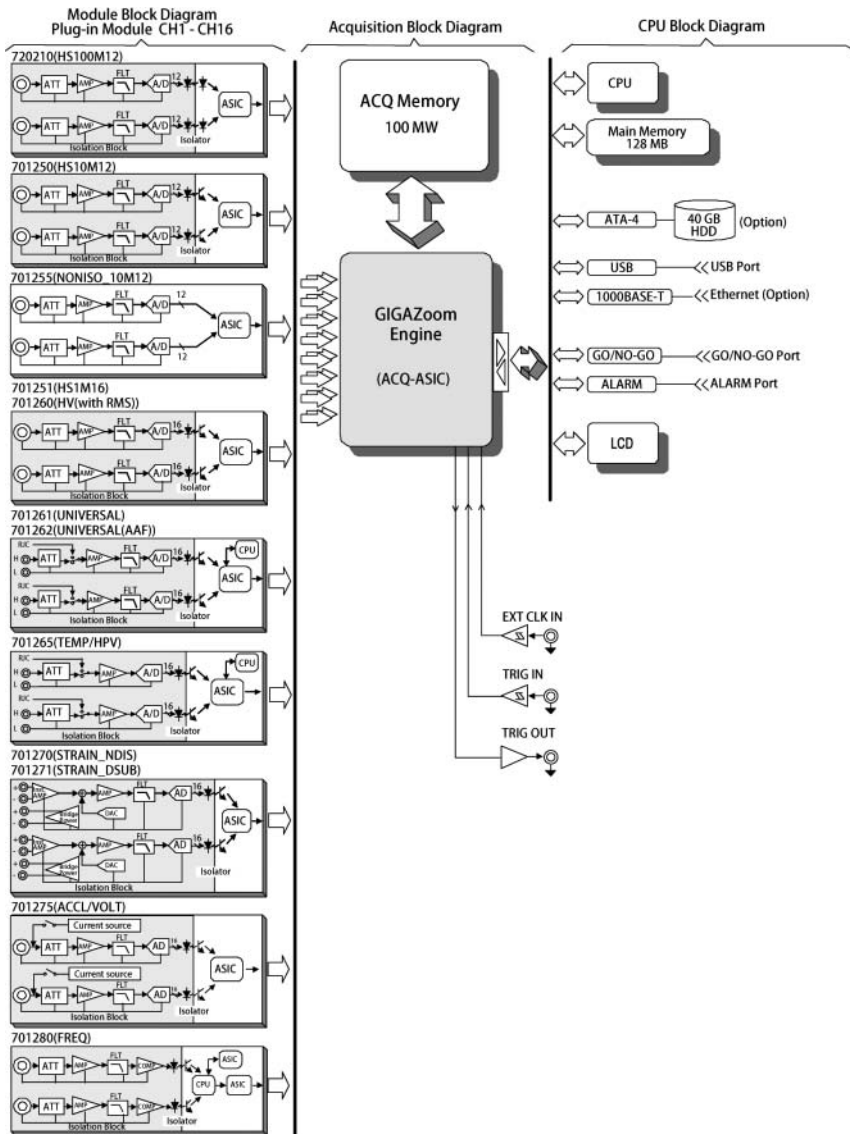

Figure 2 Overall Block Diagram of the SL1000

memory, reading and compressing data from acquisition memory for creating display data, reading data from acquisition memory for saving, etc.

DDR2 memory is used for the acquisition memory to realize high-volume and high-speed writing/reading to/from the acquisition memory.

A  $128 \times 64$  LCD is adopted, allowing system status, module status, error information, and communication parameters, etc. to be checked on the main unit.

USB 2.0 and Ethernet 1000BASE-T (optional) are available as external interfaces, enabling high-speed communication with a PC.

As for mass storage, a 40 Gbytes HDD (optional) can be installed in the main unit to store a large amount of data in real-time. The data can be saved in both a PC's HDD and internal HDD simultaneously in real-time by using an above-mentioned high-speed interface with a PC. The data can be continuously recorded at the maximum speed of 1.6 MS/s ( $100 \text{ kS/s} \times 16 \text{ channels}$ ).

### FEATURE OF HIGH-SPEED AND HIGH-ISOLATION MODULE 720210

The newly developed input module 720210 is capable of high-speed data acquisition with sample rate of 100 MS/s, A/D resolution of 12 bits, and frequency bandwidth of 20 MHz, as well as achieves 1-kV high-voltage isolation.

To realize this high-speed sample rate and high-voltage isolation, we have developed an isolation method to optically convert data digitalized in the module and send the data to the main unit through optical fiber. Figure 3 shows the principles of this method. Input signals are normalized at the amplifier and digitalized at the A/D converter in the module. The digitalized data is converted to serial data, then converted to the optical signal by a semiconductor laser diode (LD), and sent to the main unit through optical fiber. In the main unit, a photodiode (PD) is used to convert the optical signal to electrical signal, which is converted to parallel data. The clock signals are sent from the main unit to the input module in the same way. Data

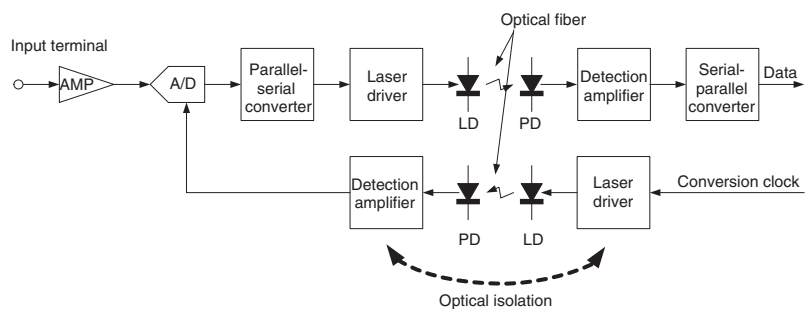

Figure 3 Principle of High Voltage Isolation

is sampled at the A/D converter synchronized to these clock signals, and data is sent from the input module to the main unit. As the data transfer speed of the semiconductor laser diode is very high, mass data transfer is achieved with just one device, which as a result, allows the insulation section to be made very compact. The optical fiber itself is insulational, and as its length is longer than the distance required for high insulation, the distance which can even withstand the high voltage of 1-kV has been realized between the signal input side and main unit. The adoption of this method thus attains 100 MS/s, 2 channels, and 1-kV high-voltage isolation in a compact module of approximately 100 × 200 mm.

### FUNCTIONS OF HIGH-SPEED DATA COMPRESSION ENGINE (GIGAZOOM ENGINE)

The emergence of high integration memory devices now allows high capacity memory to be mounted in the main unit. This allows data to be input over a long period of time with high-speed sampling. On the other hand, in order to display such data in the main memory, there is a need to send mass volumes of data to a PC, convert this data at the PC, and display it. For this reason, communication speed between the main unit and a PC poses as a bottleneck, resulting in the limits to high-speed display of waveform on a PC.

The SL1000 has high-speed data compression function (GIGAZoom Engine) in the main unit to help display the waveform at a PC at high speed.

GIGAZoom Engine has a function which compresses data on the acquisition memory in accordance with the display raster of a PC before sending the data to the PC. This means that only the compressed display data needs to be sent to a PC from the main unit, realizing high-speed waveform display.

This function allows the entire waveform input to PC memory to be displayed and checked instantaneously, even for long memories above 100 Mwords. In addition, it is also possible to compress data in any part of the acquisition memory instantaneously at the main unit, and send it to a PC and display it. Consequently, the same display update and zoom display as a standalone measuring device is realized on a PC monitor.

GIGAZoom Engine has a real-time hard disk function for recording a large amount of data in the internal HDD or PC's HDD at a specified time. Even if the amount of data exceeds 1 Gbytes, waveforms can be displayed from the compressed data.

### MULTI-SAMPLE RATE

The SL1000 is able to input data at difference sample rates for each module. Up to four sample rates are available.

This function allows data to be input at slow sample rates for slow phenomena and at fast sample rates for fast phenomena. As

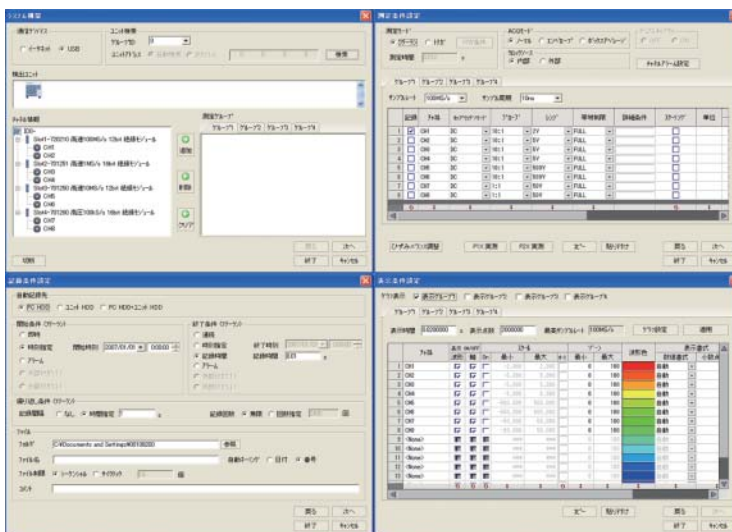

Figure 4 Setup Wizard (PC)

the timing phase differences between each sample rate are recorded, timing can be corrected for data at different sample rates based on this phase difference data. Therefore, the data of each group is displayed on the same time-axis.

### FEATURES OF ACQUISITION SOFTWARE

The acquisition software for controlling the recording operations of the SL1000 has been designed to allow intuitive operations.

When the acquisition software installed on a PC is started, this software automatically recognizes the main unit and the type of input modules connected to it.

Settings are navigated by the Setup Wizard. Figure 4 shows the Setup Wizard. It navigates settings in the order of system configuration, measuring conditions, recording conditions, and display. By setting all the tabular items, you can start measurement.

The acquisition software adopts a control panel allowing intuitive operations on the toolbar. Figure 5 shows this control panel of the acquisition software.

As shown in Figure 5, main operations, measurement start/stop, recording start/stop, pause, etc. can all be performed on this control panel.

Two modes are provided for data input in the SL1000. One is the freerun mode which continuously records measured data in real-time in both the internal HDD and the PC's HDD from the start of recording. In this mode, clicking the divide recording button on the control panel during recording divides the file at any position. Dividing files reduces the data capacity of a file, facilitating data handling at a PC. The other mode is the triggered mode which records data when the preset trigger condition is met.

The SL1000 main unit saves the setting information from a PC, which means that it can be operated in the standalone configuration without the PC connected. Operations in the

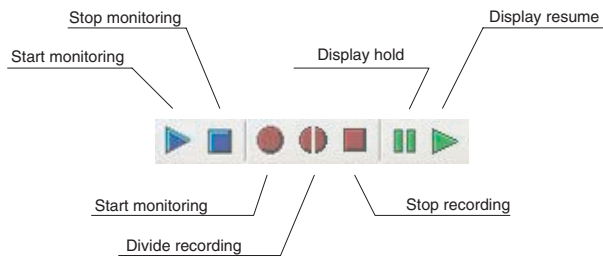
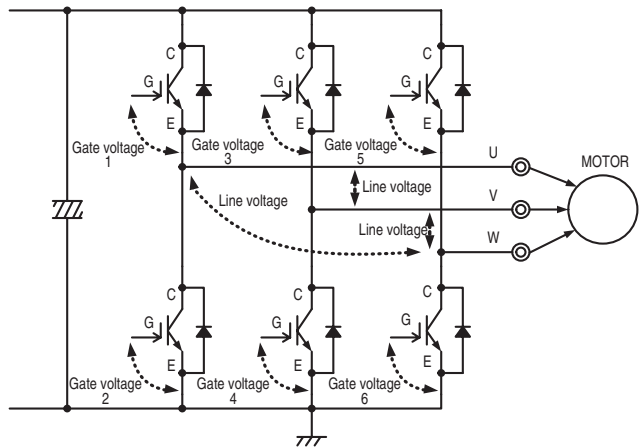

**Figure 5** Control Panel

standalone state are started with the START key on the main unit. Data is input according to the preset conditions, and data can be repeatedly saved in the internal HDD.

## APPLICATIONS

Figure 6 shows a measurement example of a motor inverter for automobiles. The development of automobile motor inverters needs to measure the voltages and timings of different parts of the inverter simultaneously. As the operating speed of the inverters switching device is increasing, the faster sampling rates are required for accurate measurement of inverter performance. Increasing power efficiency also requires accurate measurement at high voltage resolution. The operating voltage of inverters exceeds several hundred volts, and the measurements are required for not only voltage to ground but also voltage between measuring points such as the voltage between the emitter and the collector of the inverter switching device or the line voltages of three-phase motors as shown in Figure 6. This is why high isolation of input channels is indispensable. The SL1000 is capable of such measurement for applications on just one unit because it realizes 100 MS/s high-speed sampling, high A/D resolution of 12 bits, 1-kV allowable common mode voltage, and



**Figure 6** Example of Automobile Inverter Measurement

simultaneous input of multi-channels of up to 16 channels.

## CONCLUSION

This report introduced the main features and configuration of the SL1000. By making full use of its features such as multi-channel high-voltage isolation and high-speed sampling, the SL1000 will be applicable to the simultaneous observation of multiple phenomena such as high-speed and low-speed phenomena in the fields of mechatronics and power electronics including automobile applications and so forth. ◆

## REFERENCE

- (1) NAKAYAMA Etsuro, SUZUKI Satoru, UCHIDA Izuru, NIMI Yoshihisa, "ScopeCorder DL750," Yokogawa Giho, Vol. 47, No. 3, 2003, p. 111-114 in Japanese

